



EXPOSITION & EVENT SERVICES

3752 Crittenden Drive Louisville, Kentucky 40209-1122
Telephone: 502.367.0254 Fax: 502.368.0284

**Deadline to
Order Services**

February 9, 2012

**G. L. A. D. A.
Louisville New Car Show
February 24-26, 2012
Kentucky Exposition Center
Louisville, Kentucky**

SHOW MANAGEMENT: G. L. A. D. A.
3801 Springhurst Blvd., Suite 209
Louisville, KY 40241
502/238-2649
502/326-9740 Fax

MOVE-IN DATES & HOURS:

Displays:
Wednesday, February 22, 2012 1:00pm - 6:00pm
Thursday, February 23, 2012 8:00am - 6:00pm
Friday, February 24, 2012 8:00am - 3:00pm

BOOTH EQUIPMENT: Booth
7" x 44" ID Sign

Vehicles:
Vehicle Move-in timing letter will be sent two weeks prior to move-in and will be strictly enforced.

SHOW DATES & HOURS:
Friday, February 24, 2012 6:00pm - 11:00pm
Saturday, February 25, 2012 10:00am - 10:00pm
Sunday, February 26, 2012 Noon - 6:00pm

SHOW COLORS: Booth Carpet Bluejay (Blue/Black)
Aisle Carpet Black

MOVE-OUT DATE & HOURS: Sunday, February 26, 2012 6:00pm -Midnight

CARRIER CHECK IN: Sunday, February 26, 2012 by 10:00pm

Note: All display vehicles must be removed and all displays must be dismantled and ready to ship on Sunday, February 26, 2012. Please schedule your labor and outbound freight carriers accordingly

As the Official Service Contractor for this exposition, we are enclosing various equipment rental and service order forms for your information and use. In addition to the Fern Exposition & Event Services (Fern) forms, you may find forms enclosed for services performed by the Convention facility or other suppliers. Please give special attention to see that forms and payments are directed to address indicated on each order form. Some services may *not* be provided by Fern.

We realize that exhibiting in a convention can be complicated. If you need assistance or additional information that is not addressed here, please contact our Exhibitor Services Department at (502) 367-0254. We look forward to serving you.

Fern Exposition & Event Services

WAYS TO ORDER



BY INTERNET:
www.fernexpo.com



BY MAIL:
MAIL ORDER FORMS TO:
FERN EXPOSITION & EVENT SERVICES
3752 Crittenden Drive
Louisville, Kentucky 40209-1122



BY FAX:
SEND ORDER FORMS TO:
(502) 368-0284
(CREDIT CARDS ONLY)
Our FAX line is open 24 hours



BY PHONE:
Call (502) 367-0254
With Credit Card Number

Return to:



EXPOSITION & EVENT SERVICES

3752 Crittenden Drive Louisville, Kentucky 40209-1122
 Telephone: 502.367.0254 Fax: 502.368.0284

EXHIBIT FURNITURE RENTAL ORDER FORM

DEADLINE February 9, 2012
 for return of this form:

Cancellation: Cancellation after deadline will be 50% of prevailing rate.
Late Request: Request after deadline will be filled as available at the standard rate.
Color Choice: Choices not indicated will be selected by Fern.

DISPLAY TABLES - 30" high x 2' wide						DISPLAY TABLES COUNTERS - 40" high x 2' wide					
Qty.	Code	Description	Discount Rate	Standard Rate	Amount	Qty.	Code	Description	Discount Rate	Standard Rate	Amount
	223	4' long table SKIRTED 3 sides	77.25	104.25			229	4' long table SKIRTED 3 sides	98.25	132.75	
	233	6' long table SKIRTED 3 sides	98.25	132.75			239	6' long table SKIRTED 3 sides	116.50	157.25	
	253	8' long table SKIRTED 3 sides	119.00	160.75			259	8' long table SKIRTED 3 sides	139.50	188.25	
	522	4th side skirted (additional) all sizes	41.00	55.25			530	4th side skirted (additional) all sizes	54.00	73.00	
	222	4' long table NOT skirted	29.50	39.75			228	4' long table NOT skirted	38.75	52.25	
	232	6' long table NOT skirted	39.00	52.75			238	6' long table NOT skirted	49.75	67.25	
	252	8' long table NOT skirted	43.25	58.50			258	8' long table NOT skirted	54.00	73.00	
CHECK SKIRT COLOR (Includes Top Covered in White Plastic) <input type="checkbox"/> Black (4) <input type="checkbox"/> Blue (6) <input type="checkbox"/> Gold (8) <input type="checkbox"/> Burgundy (11) <input type="checkbox"/> Plum (19) <input type="checkbox"/> Green (10) <input type="checkbox"/> Gray (9) <input type="checkbox"/> Red (14) <input type="checkbox"/> Teal (18) <input type="checkbox"/> White (16)						CHECK SKIRT COLOR (Includes Top Covered in White Plastic) <input type="checkbox"/> Black (4) <input type="checkbox"/> Blue (6) <input type="checkbox"/> Gold (8) <input type="checkbox"/> Burgundy (11) <input type="checkbox"/> Plum (19) <input type="checkbox"/> Green (10) <input type="checkbox"/> Gray (9) <input type="checkbox"/> Red (14) <input type="checkbox"/> Teal (18) <input type="checkbox"/> White (16)					
CHAIRS, STOOLS, COFFEE TABLES						ACCESSORIES					
	105	Walnut Arm Chair, Grey	54.00	73.00			401	Wastebasket	13.25	18.00	
	103	Padded Side Chair, Grey	44.50	60.00			409	Chrome Bag Stand	73.25	99.00	
	101	Armless Side Chair, Black	41.50	56.00			407	Easel, tripod	22.50	30.50	
	121	Swivel Desk Chair	63.00	85.00			413	Chrome Clothes Tree	34.00	46.00	
	131	Stool - Padded with Back	45.00	60.75			435	Chrome Stanchion	22.25	30.00	
	204	Pedestal Table - 24" Dia. 18" ht.	63.00	85.00		ft.	437	White Plastic Chain (per ft.)	2.45	3.31	
	206	Pedestal Table - 24" Dia. 30" ht.	71.00	95.75			415	Garment Rack - 5' long	56.00	75.50	
	208	Pedestal Table - 24" Dia. 40" ht.	80.00	108.00		ft.	507	Special Skirting, 30" ht.	6.75	9.10	
	207	Pedestal Table - 30" Dia. 18" ht.	71.00	95.75		ft.	509	Special Skirting, 40" ht.	9.05	12.20	
	215	Pedestal Table - 30" Dia. 30" ht.	80.00	108.00			CHECK SPECIAL SKIRTING COLOR <input type="checkbox"/> Black (4) <input type="checkbox"/> Blue (6) <input type="checkbox"/> Gold (8) <input type="checkbox"/> Burgundy (11) <input type="checkbox"/> Plum (19) <input type="checkbox"/> Green (10) <input type="checkbox"/> Gray (9) <input type="checkbox"/> Red (14) <input type="checkbox"/> Teal (18) <input type="checkbox"/> White (16)				
	216	Pedestal Table - 30" Dia. 40" ht.	87.75	118.50							
	209	Pedestal Table - 36" Dia. 18" ht.	80.00	108.00							
	224	Pedestal Table - 36" Dia. 30" ht.	87.75	118.50							
	225	Pedestal Table - 36" Dia. 40" ht.	96.50	130.25							
TABLETOP RISERS - 12" Deep Covered White Plastic						SPECIAL BOOTH DRAPERIES					
	270	4' long, Single Step, 12" ht.	17.75	24.00		ft.	541	Special color siderail drapes, 36" high - Price per linear foot.	9.05	12.20	
	272	6' long, Single Step, 12" ht.	27.50	37.25		ft.	543	Special color background drapes, 8' high - Price per linear foot.	13.30	17.95	
	274	8' long, Single Step, 12" ht.	39.00	52.75			CHECK DRAPERY COLOR <input type="checkbox"/> Black (4) <input type="checkbox"/> Blue (6) <input type="checkbox"/> Gold (8) <input type="checkbox"/> Burgundy (11) <input type="checkbox"/> Plum (19) <input type="checkbox"/> Green (10) <input type="checkbox"/> Gray (9) <input type="checkbox"/> Red (14) <input type="checkbox"/> Teal (18) <input type="checkbox"/> White (16)				

Yes, I have completed and enclosed the Payment Form
 No credit will be given after close of event on items or services ordered, but not received. If you have a problem please see the Fern Service Desk Personnel at the event site prior to leaving.

Sub Total: \$ _____
6% State tax: \$ _____
TOTAL: \$ _____

Name of Event G.L.A.D.A. #4-1783-12 Booth# _____ Phone () _____
 Firm Name _____ Fax # () _____
 Address _____ E-Mail _____
 Street City State Zip Code
 Print/Type Name _____ Signature _____ Date _____

For other carpet color options, check out our discount carpet prices.

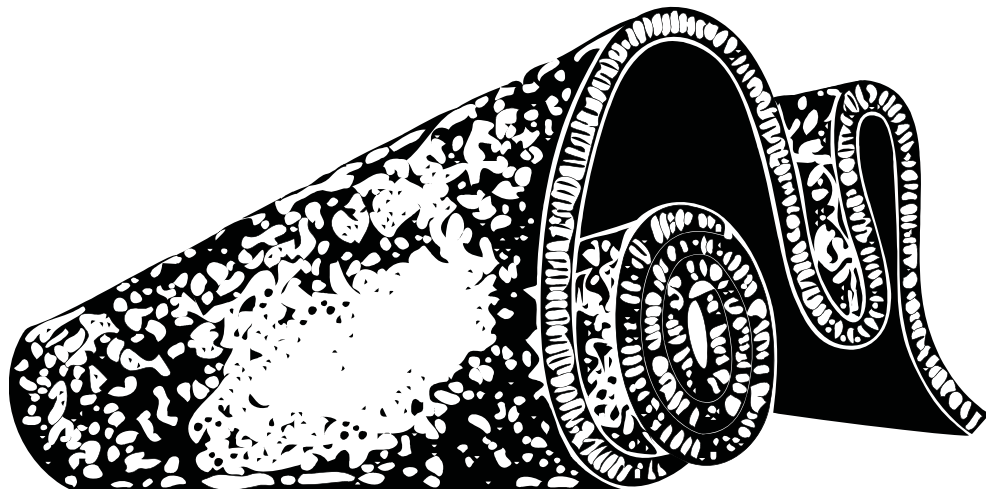

(40% discount off of 2011 prices)

Return to:



EXPOSITION & EVENT SERVICES

3752 Crittenden Drive Louisville, Kentucky 40209-1122
 Telephone: 502.367.0254 Fax: 502.368.0284

CARPET RENTAL ORDER FORM

DEADLINE February 9, 2012
 for return of this form:

Cancellation: Cancellation after deadline will be 50% of prevailing rate.
Late Request: Request after deadline will be filled as available at the standard rate.
Color Choice: Choices not indicated will be selected by Fern.

PLUSH CARPET

Plush carpet is an upgraded 34oz. carpet, available in 12 decorator colors. Swatches will be sent to you upon request.

Cut carpet is designed for use in standard size exhibit booths. If complete area carpet for your space is desired, order by the complete area square footage. Complete area carpet includes trimming, seaming, wastage, edge taping, rental and removal for carpet specifically cut to your exact measurements.

CARPET & PADDING PACKAGE	DISCOUNT RATE	STANDARD RATE	CARPET ONLY	DISCOUNT RATE	STANDARD RATE
<input type="checkbox"/> 10 ft x 10 ft Carpet & Padding (335)-----	\$ 254.00	\$ 343.00	<input type="checkbox"/> 10 ft x 10 ft Carpet only (331)-----	\$ 189.50	\$ 255.75
<input type="checkbox"/> 10 ft x 20 ft Carpet & Padding (336)-----	\$ 508.25	\$ 686.25	<input type="checkbox"/> 10 ft x 20 ft Carpet only (332)-----	\$ 379.00	\$ 511.75
<input type="checkbox"/> 10 ft x 30 ft Carpet & Padding (337)-----	\$ 762.25	\$ 1,029.00	<input type="checkbox"/> 10 ft x 30 ft Carpet only (333)-----	\$ 568.50	\$ 767.50
<input type="checkbox"/> 10 ft x 40 ft Carpet & Padding (338)-----	\$ 1,016.50	\$ 1,372.25	<input type="checkbox"/> 10 ft x 40 ft Carpet only (334)-----	\$ 758.00	\$ 1,023.25

Plush Complete Area Carpet (minimum order 1,000 sq/ft.)

	DISCOUNT RATE	STANDARD RATE	TOTAL
<input type="checkbox"/> Plush Carpet Sq/ft. (328) _____ FT x _____ FT = _____ SQ FT @	\$ 2.25 / sq.ft.	\$ 3.00 / sq.ft.	= \$ _____
<input type="checkbox"/> Padded Area Size (350) _____ FT x _____ FT = _____ SQ FT @	\$.76 / sq.ft.	\$ 1.03 / sq.ft.	= \$ _____
<input type="checkbox"/> Plastic Covering Area (360) _____ FT x _____ FT = _____ SQ FT @	\$.14 / sq.ft.	\$.19 / sq.ft.	= \$ _____

CHECK COLOR DESIRED FOR PLUSH CARPET:

- | | | | |
|--|--|--|---|
| <input type="checkbox"/> White - (63) | <input type="checkbox"/> Burgundy - (48) | <input type="checkbox"/> Gray Pearl - (64) | <input type="checkbox"/> Blue Mist - (68) |
| <input type="checkbox"/> French Beige - (65) | <input type="checkbox"/> Mocha - (61) | <input type="checkbox"/> Charcoal - (66) | <input type="checkbox"/> Colony Blue - (62) |
| <input type="checkbox"/> Cherry Red - (46) | <input type="checkbox"/> Emerald - (67) | <input type="checkbox"/> Ebony - (47) | <input type="checkbox"/> Berry - (51) |

TRADITIONAL CARPET

Cut carpet is designed for use in standard size exhibit booths. If complete area carpet for your space is desired, order by the complete area square footage. Complete area carpet includes trimming, seaming, wastage, edge taping, rental and removal for carpet specifically cut to your exact measurements.

CARPET & PADDING PACKAGE	DISCOUNT RATE	STANDARD RATE	CARPET ONLY	DISCOUNT RATE	STANDARD RATE
<input type="checkbox"/> 9 ft x 10 ft Carpet & Padding (309)-----	\$ 187.75	\$ 253.50	<input type="checkbox"/> 9 ft x 10 ft Carpet only (301)-----	\$ 129.50	\$ 174.75
<input type="checkbox"/> 9 ft x 20 ft Carpet & Padding (310)-----	\$ 375.25	\$ 506.50	<input type="checkbox"/> 9 ft x 20 ft Carpet only (302)-----	\$ 259.00	\$ 349.75
<input type="checkbox"/> 9 ft x 30 ft Carpet & Padding (311)-----	\$ 563.00	\$ 760.00	<input type="checkbox"/> 9 ft x 30 ft Carpet only (303)-----	\$ 388.50	\$ 524.50
<input type="checkbox"/> 9 ft x 40 ft Carpet & Padding (312)-----	\$ 750.50	\$ 1,013.25	<input type="checkbox"/> 9 ft x 40 ft Carpet only (304)-----	\$ 518.00	\$ 699.25

Traditional Complete Area Carpet (minimum order 1,000 sq/ft.)

	DISCOUNT RATE	STANDARD RATE	TOTAL
<input type="checkbox"/> Traditional Carpet Sq/ft. (314) _____ FT x _____ FT = _____ SQ FT @	\$ 1.75 / sq.ft.	\$ 2.35 / sq.ft.	= \$ _____
<input type="checkbox"/> Padded Area Size (350) _____ FT x _____ FT = _____ SQ FT @	\$.76 / sq.ft.	\$ 1.03 / sq.ft.	= \$ _____
<input type="checkbox"/> Plastic Covering Area (360) _____ FT x _____ FT = _____ SQ FT @	\$.14 / sq.ft.	\$.19 / sq.ft.	= \$ _____

CHECK COLOR DESIRED FOR TRADITIONAL CARPET:

- | | | | | | | | |
|------------------------------------|------------------------------------|-----------------------------------|-------------------------------------|--------------------------------------|------------------------------------|---------------------------------------|---------------------------------------|
| <input type="checkbox"/> Blue (06) | <input type="checkbox"/> Gray (09) | <input type="checkbox"/> Red (14) | <input type="checkbox"/> Black (04) | <input type="checkbox"/> Maroon (11) | <input type="checkbox"/> Plum (19) | <input type="checkbox"/> Seafoam (20) | <input type="checkbox"/> Madison (80) |
|------------------------------------|------------------------------------|-----------------------------------|-------------------------------------|--------------------------------------|------------------------------------|---------------------------------------|---------------------------------------|

Yes, I have completed and enclosed the Payment Form

No credit will be given after close of event on items or services ordered, but not received. If you have a problem please see the Fern Service Personnel at the event site prior to opening.

Sub Total: \$ _____
 6% State tax: \$ _____
TOTAL: \$ _____

Name of Event G.L.A.D.A. #4-1783-12 Booth# _____ Phone () _____
 Firm Name _____ Fax # () _____
 Address _____ E-Mail _____
 Street City State Zip Code
 Print/Type Name _____ Signature _____ Date _____

Return to:



CUSTOM FURNITURE RENTAL ORDER FORM

DEADLINE February 9, 2012
for return of this form:

3752 Crittenden Drive Louisville, Kentucky 40209-1122
Telephone: 502.367.0254 Fax: 502.368.0284

CANCELLATION: Cancellation after deadline will be charged at 75% of prevailing rate.
LATE REQUEST: Request after deadline will be filled as available at the standard rate.

Qty.	Description	Discount	Standard	Qty.	Description	Discount	Standard
____	(3401) LC-8001 Miami Left Arm Unit White Leather	\$ 494.00	\$ 741.00	____	(3463) LC-608 Pacifica Sofa Plum Velour	\$ 625.00	\$ 937.50
____	(3402) LC-8003 Miami Chaise White Leather	\$ 494.00	\$ 741.00	____	(3467) LC-607 Pacifica Club Chair Plum Velour	\$ 456.00	\$ 684.00
____	(3403) LC-8004 Miami Tail Ottoman White Leather	\$ 369.00	\$ 553.50	____	(3471) LC-617 Pacifica Bench Plum Velour	\$ 325.00	\$ 487.50
____	(3404) LC-8002 Miami Armless White Leather	\$ 494.00	\$ 741.00	____	(3475) FL-102 Floor Lamp Black/Chrome	\$ 162.50	\$ 244.00
____	(3405) LC-8006 Miami Round Ottoman White Leather	\$ 369.00	\$ 553.50	____	(3476) LC-703 Cube Black Micro Suede	\$ 106.00	\$ 159.00
____	(3406) LC-6004 Boca Corner Unit White Leather	\$ 369.00	\$ 553.50	____	(3477) LC-712 Cube Titan White	\$ 106.00	\$ 159.00
____	(3407) LC-6004B Boca Corner Unit Black Leather	\$ 369.00	\$ 553.50	____	(3478) LC-702 Cube Red Micro Suede	\$ 106.00	\$ 159.00
____	(3408) LC-6002 Boca Armless Unit White Leather	\$ 311.00	\$ 466.50	____	(3479) LC-704 Cube Sunflower Fabric	\$ 106.00	\$ 159.00
____	(3409) LC-6002B Boca Armless Unit Black Leather	\$ 311.00	\$ 466.50	____	(3480) LC-701 Cube Concentric Print Red Fabric	\$ 106.00	\$ 159.00
____	(3410) LC-6001 Vero White High Back Corner Leather	\$ 431.00	\$ 646.50	____	(3481) LC-708 Kobe Citrus Micro Suede	\$ 194.00	\$ 291.00
____	(3411) LC-6000 Vero White High Back Armless Leather	\$ 369.00	\$ 553.50	____	(3482) LC-706 Kobe Black Micro Suede	\$ 194.00	\$ 291.00
____	(3412) LC-800 Malibu Sofa White Leather	\$ 744.00	\$ 1,116.00	____	(3483) LC-707 Kobe Plum Micro Suede	\$ 194.00	\$ 291.00
____	(3413) LC-803 Malibu Sofa Red Leather	\$ 744.00	\$ 1,116.00	____	(3484) LC-709 Kobe Tangerine Micro Suede	\$ 194.00	\$ 291.00
____	(3414) LC-801 Malibu Chair & Half White Leather	\$ 594.00	\$ 891.00	____	(3485) TO-601 Sterling Coffee Table	\$ 206.00	\$ 309.00
____	(3415) LC-804 Malibu Chair & Half Red Leather	\$ 594.00	\$ 891.00	____	(3486) TO-602 Sterling End Table	\$ 194.00	\$ 291.00
____	(3416) LC-802 Malibu Bench White Leather	\$ 500.00	\$ 750.00	____	(3487) TO-501 Hampton Coffee Table	\$ 212.50	\$ 319.00
____	(3417) LC-805 Malibu Bench Red Leather	\$ 500.00	\$ 750.00	____	(3488) TO-502 Hampton End Table	\$ 206.00	\$ 309.00
____	(3418) LC-603 Barcelona Club Chair White Leather	\$ 456.00	\$ 684.00	____	(3489) TO-101 Westchester Coffee Table	\$ 219.00	\$ 328.50
____	(3419) LC-601 Barcelona Club Chair Red Leather	\$ 456.00	\$ 684.00	____	(3490) TO-102 Westchester End Table	\$ 200.00	\$ 300.00
____	(3420) LC-605 Barcelona Club Chair Black Leather	\$ 456.00	\$ 684.00	____	(3491) TO-401 Hamilton Coffee Table	\$ 231.00	\$ 337.50
____	(3421) LC-604 Barcelona Ottoman White Leather	\$ 219.00	\$ 328.50	____	(3492) TO-402 Hamilton End Table	\$ 225.00	\$ 346.50
____	(3422) LC-602 Barcelona Ottoman Red Leather	\$ 219.00	\$ 328.50	____	(3493) TO-201 Princeton Coffee Table	\$ 212.50	\$ 319.00
____	(3423) LC-606 Barcelona Ottoman Black Leather	\$ 219.00	\$ 328.50	____	(3494) TO-202 Princeton End Table	\$ 206.00	\$ 309.00
____	(3424) LC-612 Paloma Swivel Chair Red Leather	\$ 262.50	\$ 394.00	____	(3495) TO-605 Cube Table Black (24" x 24" x 21")	\$ 294.00	\$ 441.00
____	(3425) LC-613 Paloma Swivel Chair Charcoal Leather	\$ 262.50	\$ 394.00	____	(3497) TO-603 Cube Table Black (24" x 24" x 16")	\$ 237.50	\$ 356.00
____	(3426) LC-9031B St. Tropez Arm Chair Black	\$ 437.50	\$ 656.00	____	(3499) TO-604 Cube Table Black (30" x 30" x 16")	\$ 275.00	\$ 412.50
____	(3426) LC-9031W St. Tropez Arm Chair White	\$ 437.50	\$ 656.00	____	(3501) LB-3005 LED Buffet Table	\$1,249.00	\$1,973.50
____	(3428) LC-9031Y St. Tropez Arm Chair Yellow	\$ 437.50	\$ 656.00	____	(3502) LB-3003 LED Communal Table	\$1,499.00	\$2,248.50
____	(3429) LC-9031R St. Tropez Arm Chair Red	\$ 437.50	\$ 656.00	____	(3503) LB-3000 LED Light Bar	\$1,244.00	\$1,866.00
____	(3430) LC-9030R St. Tropez Armless Chair Red	\$ 406.00	\$ 609.00	____	(3504) LB-3001 High Bar Table	\$ 869.00	\$1,303.50
____	(3431) LC-9030W St. Tropez Armless Chair White	\$ 406.00	\$ 609.00	____	(3505) AC-112B Bar - Black	\$ 337.50	\$ 506.00
____	(3432) LC-9030Y St. Tropez Armless Chair Yellow	\$ 406.00	\$ 609.00	____	(3506) AC-112W Bar - White	\$ 337.50	\$ 506.00
____	(3433) LC-9030B St. Tropez Armless Chair Black	\$ 406.00	\$ 609.00	____	(3507) AC-201 Extension Bar	\$ 431.00	\$ 646.50
____	(3434) LC-611 Sausalito Sofa Black Microfiber	\$ 506.00	\$ 759.00	____	(3508) AC-200 Corner Bar	\$ 431.00	\$ 646.50
____	(3435) LC-609 Sausalito Club Chair Black Microfiber	\$ 325.00	\$ 487.50	____	(3509) SB-202 Silk Black Bar Stool	\$ 187.50	\$ 281.00
____	(3436) LC-618 Sausalito Club Chair Blue Microfiber	\$ 381.00	\$ 571.50	____	(3510) SB-203 Bombe-Bar Stool	\$ 212.50	\$ 319.00
____	(3437) LC-610 Sausalito Loveseat Black Microfiber	\$ 462.50	\$ 694.00	____	(3511) SB-208 Trave-Bar Stool	\$ 212.50	\$ 319.00
____	(3438) LC-303 Princeton Sofa Black Leather	\$ 587.50	\$ 881.00	____	(3512) SB-201 Lennox Bar Stool	\$ 212.50	\$ 319.00
____	(3439) LC-301 Princeton Club Chair Black Leather	\$ 425.00	\$ 637.50	____	(3513) SB-204 Euro Black Bar Stool	\$ 187.50	\$ 281.00
____	(3440) LC-302 Princeton Loveseat Black Leather	\$ 519.00	\$ 778.50	____	(3514) SB-209 Park Ave Bar Stool	\$ 200.00	\$ 300.00
____	(3441) LC-614 Tribeca Sectional Black Microfiber	\$ 325.00	\$ 487.50	____	(3515) SB-505W Hourglass Bar Stool-White	\$ 206.00	\$ 309.00
____	(3442) LC-615 Tribeca Corner Black Microfiber	\$ 356.00	\$ 534.00	____	(3516) SB-505B Hourglass Bar Stool-Black	\$ 206.00	\$ 309.00
____	(3443) LC-616 Tribeca Bench Black Microfiber	\$ 325.00	\$ 487.50	____	(3517) SB-501W Napa Stool	\$ 200.00	\$ 300.00
____	(3444) LC-403 Cambridge Sofa Champagne Velour	\$ 569.00	\$ 853.50	____	(3518) SD-100 Drafting Stool Black w/Arms	\$ 219.00	\$ 328.50
____	(3445) LC-401 Cambridge Club Chair Champagne Velour	\$ 381.00	\$ 571.50	____	(3519) SD-101 Drafting Stool Black w/out Arms	\$ 212.50	\$ 319.00
____	(3446) LC-402 Cambridge Loveseat Champagne Velour	\$ 500.00	\$ 750.00	____	(3520) CH-800W Panton Chair - White	\$ 156.00	\$ 234.00
____	(3447) LC-103 Westchester Sofa Cognac Leather	\$ 650.00	\$ 975.00	____	(3521) CH-800B Panton Chair - Black	\$ 156.00	\$ 234.00
____	(3448) LC-101 Westchester Club Chair Cognac Leather	\$ 437.50	\$ 656.00	____	(3522) CH-307 Silk Black Chair w/out Arms	\$ 119.00	\$ 178.50
____	(3449) LC-705 Westchester Ottoman Cognac Leather	\$ 219.00	\$ 628.50	____	(3523) CH-308 Silk Black Chair w/Arms	\$ 125.00	\$ 187.50
____	(3450) LC-102 Westchester Loveseat Cognac Leather	\$ 569.00	\$ 853.50	____	(3524) CH-301 Euro Black Chair w/out Arms	\$ 106.00	\$ 159.00
____	(3451) LC-203 Manhattan Sofa Pewter Velour	\$ 575.00	\$ 862.50	____	(3525) CH-302 Euro Black Chair w/Arms	\$ 112.50	\$ 169.00
____	(3455) LC-201 Manhattan Club Chair Pewter Velour	\$ 387.50	\$ 581.00	____	(3526) CH-309 Euro Maple Chair	\$ 150.00	\$ 225.00
____	(3459) LC-202 Manhattan Loveseat Pewter Velour	\$ 500.00	\$ 750.00	____	(3527) CH-311 Park Ave. Cafe Chair	\$ 175.00	\$ 262.50

Yes, I have completed and enclosed the **Payment Form**



Sub Total: \$ _____
6% State tax: \$ _____
TOTAL: \$ _____

No credit will be given after close of event on items or services ordered, but not received. If you have a problem please see Fern Service Personnel at the event site prior to opening.

Charges listed above include delivery to your booth, rental (not sale) during the event, and removal.

Name of Event G.L.A.D.A. #4-1783-12 Booth# _____ Phone () _____
Firm Name _____ Fax # () _____
Address _____ E-Mail _____
Street City State Zip Code
Print/Type Name _____ Signature _____ Date _____

Return to:



CUSTOM FURNITURE RENTAL ORDER FORM

DEADLINE February 9, 2012
for return of this form:

3752 Crittenden Drive Louisville, Kentucky 40209-1122
Telephone: 502.367.0254 Fax: 502.368.0284

CANCELLATION: Cancellation after deadline will be charged at 75% of prevailing rate.
LATE REQUEST: Request after deadline will be filled as available at the standard rate.

Qty.	Description	Discount	Standard	Qty.	Description	Discount	Standard
___ (3528)	CH-900 Queen Anne Chair	\$ 162.50	\$ 244.00	___ (3588)	BC-103 Contemporary Grey Bookcase	\$ 406.00	\$ 609.00
___ (3529)	CH-904 Traditional Mahogany Chair	\$ 237.50	\$ 356.00	___ (3589)	CR-100 Contemporary Grey Credenza	\$ 462.50	\$ 694.00
___ (3530)	CH-905 Traditional Mahogany Chair w/casters	\$ 244.00	\$ 366.00	___ (3590)	DE-102 Grey Desk	\$ 469.00	\$ 703.50
___ (3531)	CH-907 Parson Chair	\$ 162.50	\$ 244.00	___ (3591)	CR-212 Maple Credenza	\$ 562.50	\$ 844.00
___ (3532)	TB-103 Lennox Bar Table	\$ 256.00	\$ 384.00	___ (3592)	DE-136 Maple Desk Single Pedestal	\$ 587.50	\$ 881.00
___ (3533)	TB-102 Bombe Bar Table	\$ 294.00	\$ 441.00	___ (3593)	DE-131 Maple Desk Double Pedestal	\$ 594.00	\$ 891.00
___ (3534)	TB-206 Silk Bar Table 30" Dia	\$ 212.50	\$ 319.00	___ (3594)	LF-206 Maple Lateral File	\$ 394.00	\$ 591.00
___ (3535)	TB-207 Silk Bar Table 36" Dia	\$ 219.00	\$ 328.50	___ (3595)	CR-205 Walnut Credenza	\$ 562.50	\$ 844.00
___ (3536)	TB-100 Trave Bar Table	\$ 294.00	\$ 441.00	___ (3596)	DE-206 Walnut Desk Double Pedestal	\$ 525.00	\$ 787.50
___ (3537)	TC-504 Euro Chrome Bar Table 30" Dia	\$ 212.50	\$ 319.00	___ (3597)	DE-201 Walnut Desk Exe Double Pedestal	\$ 575.00	\$ 862.50
___ (3539)	TC-505 Euro Chrome Bar Table 36" Dia	\$ 219.00	\$ 328.50	___ (3598)	LF-204 Walnut Lateral File	\$ 387.50	\$ 581.00
___ (3541)	TC-108 Euro Chrome Bar Table 42" Dia	\$ 225.00	\$ 337.50	___ (3599)	BC-107 Bookcase Mahogany	\$ 562.50	\$ 844.00
___ (3543)	TC-502 Euro Black Cafe Table 30" Dia	\$ 212.50	\$ 319.00	___ (3661)	BC-109 Bookcase Walnut	\$ 425.00	\$ 637.50
___ (3545)	TC-503 Euro Black Cafe Table 36" Dia	\$ 219.00	\$ 328.50	___ (3662)	CR-301 Mahogany Credenza	\$ 619.00	\$ 928.50
___ (3547)	TC-107 Euro Black Cafe Table 42" Dia	\$ 225.00	\$ 337.50	___ (3663)	DE-300 Mahogany Desk Double Pedestal	\$ 619.00	\$ 928.50
___ (3549)	TB-204 Euro Black Bar Table 30" Dia	\$ 212.50	\$ 319.00	___ (3664)	LF-101 Lateral File 2 Drawer Grey	\$ 356.00	\$ 534.00
___ (3551)	TB-205 Euro Black Bar Table 36" Dia	\$ 219.00	\$ 328.50	___ (3665)	LF-106 Lateral File 2 Drawer Black	\$ 356.00	\$ 534.00
___ (3553)	TC-500 Park Ave Cafe Table 30" Dia	\$ 212.50	\$ 319.00	___ (3666)	AC-111 Refrigerator Compact	\$ 362.50	\$ 544.00
___ (3554)	TC-501 Park Ave Cafe Table 36" Dia	\$ 219.00	\$ 328.50	___ (3667)	PE-101 Pedestal Black 14" w x 14"d x 42"h	\$ 300.00	\$ 450.00
___ (3555)	TB-200 Park Ave Bar Table 30" Dia	\$ 212.50	\$ 319.00	___ (3668)	PE-102 Pedestal Black 14" w x 14"d x 36"h	\$ 256.00	\$ 384.00
___ (3556)	TB-201 Park Ave Bar Table 36" Dia	\$ 219.00	\$ 328.50	___ (3669)	PE-103 Pedestal Black 14" w x 14"d x 30"h	\$ 231.00	\$ 346.50
___ (3557)	TC-102 Euro Maple Cafe Table 42" Dia	\$ 244.00	\$ 366.00	___ (3670)	PE-106 Pedestal Grey 14" w x 14"d x 42"h	\$ 300.00	\$ 450.00
___ (3558)	BC-121 Carmel-Etagere	\$ 519.00	\$ 778.50	___ (3671)	PE-107 Pedestal Grey 14" w x 14"d x 36"h	\$ 256.00	\$ 384.00
___ (3559)	CH-200 Conference Chair Mid Back	\$ 212.50	\$ 319.00	___ (3672)	PE-108 Pedestal Grey 14" w x 14"d x 30"h	\$ 231.00	\$ 346.50
___ (3560)	CH-201 Conference Chair High Back	\$ 225.00	\$ 337.50	___ (3673)	PE-111 Pedestal White 14" w x 14"d x 42"h	\$ 300.00	\$ 450.00
___ (3561)	CH-202 Conference Chair Fabric Sled Base	\$ 200.00	\$ 300.00	___ (3674)	PE-112 Pedestal White 14" w x 14"d x 36"h	\$ 256.00	\$ 384.00
___ (3562)	CH-100 Conference Chair Mid Back Executive	\$ 237.50	\$ 356.00	___ (3675)	PE-113 Pedestal White 14" w x 14"d x 30"h	\$ 231.00	\$ 346.50
___ (3563)	CH-101 Conference Chair High Back Executive	\$ 281.00	\$ 421.50	___ (3676)	PE-104 Pedestal Black 24" x 24"d x 36" h	\$ 362.50	\$ 544.00
___ (3564)	CH-102 Conference Chair Leather Sled Base	\$ 231.00	\$ 346.50	___ (3677)	PE-109 Pedestal Grey 24" x 24"d x 36" h	\$ 362.50	\$ 544.00
___ (3565)	CH-400 Task Chair w/Arms	\$ 162.50	\$ 244.00	___ (3678)	PE-114 Pedestal White 24" x 24"d x 36" h	\$ 362.50	\$ 544.00
___ (3566)	CH-401 Task Chair wo/Arms	\$ 169.00	\$ 253.50	___ (3679)	SR-100 Stanchion Chrome	\$ 75.00	\$ 112.50
___ (3567)	CH-203 Conference Chair High Back Fabric	\$ 225.00	\$ 337.50	___ (3680)	SR-101 Stanchion Rope 6' Red Velour	\$ 62.50	\$ 94.00
___ (3568)	CH-908 Traditional Mahogany Chair Leather	\$ 294.00	\$ 441.00	___ (3681)	AC-100 Coat Tree	\$ 112.50	\$ 169.00
___ (3569)	TC-600 Conference Table 6' Maple Rectangle	\$ 519.00	\$ 778.50	___ (3682)	ES-100 Easel Wood/Oak	\$ 112.50	\$ 169.00
___ (3570)	CH-102 Conference Chair Leather Rectangle	\$ 562.50	\$ 884.00	___ (3683)	AC-104 Literature Rack Black/Metal	\$ 162.50	\$ 244.00
___ (3571)	TC-312 Conference Table 6' Black Oval	\$ 519.00	\$ 778.50	Following items listed are available in limited quantities. Please call for availability.			
___ (3572)	TC-307 Conference Table 6' Mahogany Oval	\$ 519.00	\$ 778.50	___ (3684)	TO-303 Metropolitan Console Table	\$ 244.00	\$ 366.00
___ (3573)	TC-309 Conference Table 6' Black Oval	\$ 519.00	\$ 778.50	___ (3685)	TO-302 Metroplitan End Table	\$ 200.00	\$ 300.00
___ (3574)	TC-302 Conference Table 8' Mahogany Oval	\$ 562.50	\$ 844.00	___ (3686)	TO-301 Metropolitan Coffee Table	\$ 219.00	\$ 328.50
___ (3575)	TC-303 Conference Table 8' Black Oval	\$ 562.50	\$ 844.00	___ (3687)	AC-108 Literature Stand Aluminum	\$ 175.00	\$ 262.50
___ (3696)	TC-300 Conference Table 10' Grey Oval	\$ 650.00	\$ 975.00	___ (3688)	VF-202 Vertical File 4 Drawer Black	\$ 356.00	\$ 534.00
___ (3576)	TC-301 Conference Table 10' Black Oval	\$ 650.00	\$ 975.00	___ (3689)	VF-203 Vertical File 4 Drawer Grey	\$ 356.00	\$ 534.00
___ (3577)	TC-104 Queen Anne Table 42" Dia	\$ 469.00	\$ 703.50	___ (3690)	VF-200 Vertical File 2 Drawer Black	\$ 181.00	\$ 271.50
___ (3578)	DE-601 Queen Anne Writing Desk	\$ 362.50	\$ 544.00	___ (3691)	VF-201 Vertical File 2 Drawer Grey	\$ 181.00	\$ 271.50
___ (3579)	TG-400 Chrome & Glass Table 5'	\$ 475.00	\$ 712.50	___ (3692)	FL-100 Corona Floor Lamp	\$ 175.00	\$ 262.50
___ (3580)	TG-403 Chrome & Glass Table 42" Dia	\$ 344.00	\$ 516.00	___ (3693)	TL-100 Corona Table Lamp	\$ 100.00	\$ 150.00
___ (3581)	TG-401 Trestle Table 4'	\$ 350.00	\$ 525.00	___ (3694)	TL-101 Rialto Table Lamp	\$ 100.00	\$ 150.00
___ (3582)	TG-402 Trestle Table 32"	\$ 325.00	\$ 487.50	___ (3695)	FL-101 Up Light Floor Lamp	\$ 175.00	\$ 262.50
___ (3583)	PE-100 Storage Pedestal Black	\$ 456.00	\$ 684.00				
___ (3584)	PE-105 Storage Pedestal Grey	\$ 456.00	\$ 684.00				
___ (3585)	PE-110 Storage Pedestal White	\$ 456.00	\$ 684.00				
___ (3586)	TC-700 Computer Counter	\$ 219.00	\$ 328.50				
___ (3587)	TC-701 Computer Desk	\$ 206.00	\$ 309.00				

Yes, I have completed and enclosed the **Payment Form**



Sub Total: \$ _____
6% State tax: \$ _____
TOTAL: \$ _____

No credit will be given after close of event on items or services ordered, but not received. If you have a problem please see Fern Service Personnel at the event site prior to opening. Charges listed above include delivery to your booth, rental (not sale) during the event, and removal.

Name of Event G.L.A.D.A. #4-1783-12 Booth# _____ Phone () _____
Firm Name _____ Fax # () _____
Address _____ E-Mail _____
Street City State Zip Code
Print/Type Name _____ Signature _____ Date _____

Return to:



EXPOSITION & EVENT SERVICES

3752 Crittenden Drive Louisville, Kentucky 40209-1122
Telephone: 502.367.0254 Fax: 502.368.0284

CLEANING SERVICE ORDER FORM

DEADLINE February 9, 2012
for return of this form:

Cancellation: Cancellation of any portion of Cleaning order after deadline, and before service, will be charged at 25% of prevailing rate.

The cleaning services provided by the exhibit hall include only a general sweeping of the aisle. All rental carpets ordered from Fern are installed in clean condition. Any cleaning service required within your booth space for debris accumulated during set-up and exhibit hours should be ordered below.

VACUUMING / SHAMPOO

All rates are based on the total square footage of your exhibit space. (100 square foot minimum)

Please check preference below:

- (903) DAILY - Vacuum carpet, empty wastebaskets and clean ashtrays before initial opening of exhibit and DAILY thereafter \$.30 Per Sq./ft. per day
(931) DAILY - Over 1000 Sq.Ft. \$.25 Per Sq./ft. per day
(901) ONCE Vacuum carpet, empty wastebaskets and clean ashtrays ONCE before opening of exhibit \$.33 Per Sq./ft.
(905) SHAMPOO - ONCE before initial opening of exhibit \$.55 Per Sq./ft.
There will be an additional charge for cleaning carpets that are subjected to excessive wear and tear such as wood or metal shavings generated by demonstrations in the booth, food sampling, landscape, etc.

PORTER SERVICE

Empty wastebasket and police exhibit space at two hour intervals during show hours.

- (915) Periodical Porter Service \$214.00 Per Day

Please check preference below:

- DAILY
ONCE --- Specify Day: Date:
OTHER --- Specify Day(s) Date(s)

DISPLAY WIPE DOWN

- (919) Display Wipe Down before initial opening (4 Hour minimum per day) \$ 60.00 per hr. S/T or \$120.00 per hr. O/T
(920) Display Wipe Down daily (4 Hour minimum per day) \$ 60.00 per hr. S/T or \$120.00 per hr. O/T

SPECIAL INSTRUCTIONS / CONCERNS

ESTIMATE CLEANING SERVICES COST FOR ADVANCE PAYMENT

* Exhibit Space: ft. x ft. = sq. ft. (100 sq. ft. min.) x per sq. ft. x days = \$
* Porter Service: days x per day = \$
* Display Cleaning: hours (4 Hour minimum per day) x day(s) x \$ 60.00 per hr. S/T or \$120.00 per hr. O/T = \$

Yes, I have completed and enclosed the Payment Form

No credit will be given after close of event on items or services ordered, but not received. If you have a problem please see Fern Service Personnel at the event site prior to opening.

Sub Total: \$
NO TAX ON CLEANING
TOTAL: \$

Name of Event G.L.A.D.A. #4-1783-12 Booth# Phone ()
Firm Name Fax # ()
Address Street City State Zip Code E-Mail
Print/Type Name Signature Date

Return to:



3752 Crittenden Drive Louisville, Kentucky 40209-1122
Telephone: 502.367.0254 Fax: 502.368.0284

DISPLAY LABOR SERVICE ORDER FORM

(THIS FORM IS NOT FOR UNLOADING AND RELOADING - SEE DRAYAGE SERVICE)

DEADLINE February 9, 2012

for return of this form:

Cancellation: Cancellation of any portion of labor order within 48 hours of start will be charged 1 hour minimum per man at the applicable hourly rate.

Late Request: Request received on-site will be filled as work force is available.

PLAN A - SUPERVISION BY FERN

To save time and alleviate exhibitor supervision, Plan A (Supervision by Fern) is provided so that exhibits may be installed prior to the exhibitor's arrival. All pertinent information should be directed to us, including blueprints, photographs, shipping information and set-up instructions. Professionally trained personnel are used on installation/dismantles, and where possible, all work is performed on straight time. Charge for supervised service is 30% (with a minimum of \$50.00 per installation and/or dismantle) of the total labor bill. Please provide an emergency contact telephone number: ()

Table with 4 columns: ORDER:, Number of Men Required (Minimum of two), Estimated Hours (one hour increments) Each Man, and rows for (1017) Labor for Installation and (1019) Labor for Dismantle.

PLAN B - SUPERVISION BY EXHIBITOR PERSONNEL

Starting time can be guaranteed only in those instances where men are requested for the start of the working day, which is 8:00 A.M., unless official set-up time is set to begin later in the day. While every attempt will be made to provide men at a time requested subsequent to 8:00 A.M. (or official set-up time), such starting time must be approximate, since men are assigned to jobs at the start of the day and it is impossible to gauge exact time of completion of first job assignment. It is important that exhibit representative check in at service desk to pick up labor ordered. Exhibit representative must also check the labor back in at the service desk upon completion of work. All work to be done under supervision of the exhibitor or his representative.

Table with 6 columns: ORDER:, Number of Men Required, Estimated Hours (one hour increments) Each Man, Start Time, Start Date, No. Days, and rows for (1017) Labor for Installation and (1019) Labor for Dismantle.

Supervisor will be:
Phone: ()

Note: If exhibitor fails to pick up men at time ordered, a one hour per man no-show charge will be assessed.

RATES: ESTIMATED DISPLAY LABOR COST FOR ADVANCED PAYMENT

Charges for labor service are based on prevailing rates of labor and materials. All labor before 8:00 A.M. and after 4:30 P.M. weekdays and all hours Saturday, Sunday, and holidays will be charged at overtime rate. Minimum charge one (1) hour per man, billed in one (1) hour increments. For information and cost relative to unloading and reloading please see the Shipping Information and Service Order Form enclosed. This form is not intended for the ordering of unloading/loading services. SEE DRAYAGE SERVICE FORM.

INSTALLATION

of men x # of hours per man x # of days = Total straight time hours x \$ 60.00 / hr. =
of men x # of hours per man x # of days = Total over time hours x \$ 120.00 / hr. =
Add 30% if supervised by Fern (\$ 50.00 min.) =

DISMANTLE

of men x # of hours per man x # of days = Total straight time hours x \$ 60.00 / hr. = N/A
of men x # of hours per man x # of days = Total over time hours x \$ 120.00 / hr. =
Add 30% if supervised by Fern (\$ 50.00 min.) =

NOTE:

Your company is encouraged to carry insurance covering potential damages or loss associated with your display. Fern will NOT be responsible for damage or loss of display materials. In any case, the liability of Fern will be limited to a maximum of 50% of the total labor bill, not to exceed \$1000.

Yes, I have completed and enclosed the Payment Form
No credit will be given after close of event on items or services ordered, but not received.
If you have a problem please see Fern Service Personnel at the event site prior to opening.

Sub Total: \$
NO TAX ON LABOR
TOTAL: \$

Name of Event G.L.A.D.A. #4-1783-12 Booth# Phone ()
Firm Name Fax # ()
Address Street City State Zip Code E-Mail
Print/Type Name Signature Date

Return to:



EXPOSITION & EVENT SERVICES

3752 Crittenden Drive Louisville, Kentucky 40209-1122
Telephone: 502.367.0254 Fax: 502.368.0284

FORKLIFT WITH OPERATOR SERVICE ORDER FORM

(THIS FORM IS NOT FOR UNLOADING AND RELOADING -
SEE DRAYAGE SERVICE)

DEADLINE February 9, 2012

for return of this form:

Cancellation: Cancellation of any portion of labor order within 48 hours of start will be charged 1 hour minimum per man at the applicable hourly rate.

Late Request: Request received on-site will be filled as work force is available.

LABOR WITH FORKLIFT TO RIG IN BOOTH

If your exhibit includes large header signs, cantilever structures, heavy display components or machinery which cannot be lifted in place by display carpenters, you will require a forklift with operator in your booth for installation and removal. The forklift with operator cost to the exhibitor is billed at hourly increments with a one (1) hour minimum. If additional decorators are required, prevailing decorator labor charges will be assessed. If you have forklift questions, please call Fern at 502-367-0254. **It is important that exhibit representative check in at service desk to pick up labor ordered.**

ORDER FOR FORKLIFT FOR IN-BOOTH WORK

ORDER:	Number of Men Required	Estimated Hours (one hour increments) Each Man	Start Date	Start Time	Estimated Finish Time	Estimated Total Time
(1005) Labor for Installation						
(1007) Labor for Dismantle						

RATES: ESTIMATED RIGGING LABOR COST FOR ADVANCE PAYMENT

Charges for forklift are based on prevailing rates for labor and materials. All labor before 8:00 A.M. and after 4:30 P.M. weekdays, all day Saturday, Sunday and holidays will be charged at the Overtime rate. Forklift and operator is billed at hourly rate with a minimum charge of one (1) hour per man, billed in one (1) hour increments. For information and costs related to Labor To Install Displays, Labor To Hang Signs, or Labor For Unloading Services - refer to other forms in this Service Kit.

INSTALLATION			
_____ # of Fork/operators x _____ # of hours per man x _____ # of days	_____ Total straight time hours x \$160.00 / hr.	=	_____
_____ # of Fork/operators x _____ # of hours per man x _____ # of days	_____ Total over time hours x \$220.00 / hr.	=	_____
	Add 30% if supervised by Fern (\$ 50.00 min.)	=	_____
DISMANTLE			
_____ # of Fork/operators x _____ # of hours per man x _____ # of days	_____ Total straight time hours x \$160.00 / hr.	=	N/A
_____ # of Fork/operators x _____ # of hours per man x _____ # of days	_____ Total over time hours x \$220.00 / hr.	=	_____
	Add 30% if supervised by Fern (\$ 50.00 min.)	=	_____

NOTE:

Your company is encouraged to carry insurance covering potential damages or loss associated with your display. Fern will NOT be responsible for damage or loss of display materials. In any case, the liability of Fern will be limited to a maximum of 50% of the total labor bill, not to exceed \$1000.

Yes, I have completed and enclosed the Payment Form

No credit will be given after close of event on items or services ordered, but not received. If you have a problem please see Fern Service Personnel at the event site prior to opening.



Sub Total: \$ _____

\$ **NO TAX ON LABOR** _____

TOTAL: \$ _____

Name of Event G.L.A.D.A. #4-1783-12 Booth# _____ Phone () _____

Firm Name _____ Fax # () _____

Address _____ E-Mail _____
Street City State Zip Code

Print/Type Name _____ Signature _____ Date _____

All orders are subject to the terms and conditions as outlined on the payment form.

Return to:



EXPOSITION & EVENT SERVICES

3752 Crittenden Drive Louisville, Kentucky 40209-1122
 Telephone: 502.367.0254 Fax: 502.368.0284

SHIPPING INFORMATION AND FREIGHT SERVICE ORDER FORM - PAGE 1

DEADLINE February 9, 2012

for return of this form:

Important: Complete the Freight Payment computation below based upon your estimated shipments and return this form with your payment and the Payment Authorization form included with this service kit.

INSTRUCTIONS

- All shipments must be sent prepaid. Collect shipments will not be accepted.
- The Advance Warehouse will **ONLY** accept packaged shipments, including crates, boxes and skids. Loose shipments will not be accepted unless the delivering carrier cannot deliver the shipment to the facility, in which case a 50% surcharge will be added to the warehouse rate.
- Loose, uncrated, van, or specializes carrier shipments should be sent **DIRECTLY** to the **CONVENTION FACILITY** to arrive **AFTER 8:00 AM** on the first day of the exhibitor installation.
- Consignment or delivery of a shipment to Fern or it's subcontractors by an Exhibitor or Shipper on behalf of the Exhibitor will be construed as an acceptance by the Exhibitor of the Freight Terms and Conditions on the front and reverse of this page.
- Outbound bills of lading must be filled out and turned into the exhibitor service desk. If designated carriers are to be used, the exhibitor must make those arrangements directly with the carrier. If designated carrier fails to show in required time frame, shipment will be reconsigned to house carrier. If no return information is provided, freight will be forced to house carrier.

ADVANCE RECEIVING WAREHOUSE

* Label each piece of your shipment(s) as follows:
 TO: (NAME OF EXHIBITING COMPANY)
 c/o Fern Exposition & Event Services
 3752 Crittenden Drive
 Louisville, KY 40209
 Event: G.L.A.D.A.
 Exhibitor Space #: YOUR SPACE # ASSIGNMENT
 Must arrive by: Tuesday, February 21, 2012

DIRECT TO EVENT SITE

* Label each piece of your shipment(s) as follows:
 TO: (NAME OF EXHIBITING COMPANY)
 c/o Fern Exposition & Event Services
 Kentucky Exposition Center
 937 Phillips Lane, Louisville, KY 40209
 Event: G.L.A.D.A.
 Exhibitor Space #: YOUR SPACE # ASSIGNMENT
 Target arrival on: Wednesday, February 22, 2012

FREIGHT RATE SCHEDULE

Rates below include receipt of your freight; delivery to the booth; storage; and return of empty crates; and the end of the show movement of your freight from the booth to the dock and reloading on trucks. Cost for freight per cwt (100 lbs or fraction) with a **200 lb. minimum per shipment applies.**

CATEGORY	DESCRIPTION	RECEIVED AT	RATE/CWT.
A	Crated or skidded shipments to	Advance Warehouse	66.80
B	Crated or skidded shipments via van lines or specialized carriers, Fed-Ex, UPS, or US Mail.	Advance Warehouse	83.50
C	Shipments requiring special handling, i.e. loose, uncrated, or late freight to	Advance Warehouse	100.00
D	Crated or skidded shipments to	Event Site	61.80
E	Crated or skidded shipments via van lines or specialized carriers, Fed-Ex, UPS, or US Mail.	Event Site	77.25
F	Shipments requiring special handling, i.e. loose, uncrated, or early freight to	Event Site	92.70
P	Small Package Shipment (shipments not exceeding 50 lbs per shipment) via FedEx, UPS or Overnight Carrier to the Event Site.	Event Site	\$35.00 1st carton \$15.00 ea addl carton

FREIGHT PAYMENT COMPUTATION

Enter estimated total pounds of all your shipments by rounding up each total shipment weight to the nearest 100 pounds (i.e. one 232 lb. shipment of any number of pieces would be figured as 300 lbs., 590 lbs. of any number of pieces would be figured as 600 lbs., 705 lbs. as 800 lbs., etc.) any shipment with a total of 200 lbs. or less should be calculated at 200 lb. minimum

Category (A,B,C,D,E,F)	Numbers of Pieces	Weight (Min. 200 lbs.)	Rate/CWT	Total
Shipment 1	_____	_____ lbs.	x _____	= \$ _____
Shipment 2	_____	_____ lbs.	x _____	= \$ _____
Shipment 3	_____	_____ lbs.	x _____	= \$ _____

Yes, I have completed and enclosed the Payment Form

Sub Total: \$ _____
TOTAL: \$ **NO TAX ON DRAYAGE SERVICE** _____

No credit will be given after close of event on items or services ordered, but not received. If you have a problem please see the Fern Service Desk Personnel at the event site prior to leaving.

Please be sure to read both pages of this SHIPPING INFORMATION AND DRAYAGE SERVICE ORDER FORM. Other conditions are applicable as stated on 2nd page.

Name of Event G.L.A.D.A. #4-1783-12 Booth# _____ Phone () _____
 Firm Name _____ Fax # () _____
 Address _____ E-Mail _____
 Street City State Zip Code
 Print/Type Name _____ Signature _____ Date _____

RUSH CONVENTION EXHIBIT MATERIAL

FOR ADVANCE WAREHOUSE ONLY

MUST BE RECEIVED BY:

Tuesday, February 21, 2012

To:

(Your Company Name)

**SITE: Fern Exposition & Event Services
3752 Crittenden Drive
Louisville, KY 40209**

Attn: G. L. A. D. A.

Booth Number: _____

Number _____ of _____ pieces

RUSH CONVENTION EXHIBIT MATERIAL

FOR ADVANCE WAREHOUSE ONLY

MUST BE RECEIVED BY:

Tuesday, February 21, 2012

To:

(Your Company Name)

**SITE: Fern Exposition & Event Services
3752 Crittenden Drive
Louisville, KY 40209**

Attn: G. L. A. D. A.

Booth Number: _____

Number _____ of _____ pieces

RUSH CONVENTION EXHIBIT MATERIAL

FOR DIRECT TO SHOW SITE

MUST TARGET DELIVERY FOR:

Wednesday, February 22, 2012

(Do **NOT** Deliver Before)

To:

(Your Company Name)

**SITE: Fern Exposition
Kentucky Exposition Center
937 Phillips Lane
Louisville, KY 40209
Attn: G. L. A. D. A.**

Booth Number: _____

Number _____ of _____ pieces

RUSH CONVENTION EXHIBIT MATERIAL

FOR DIRECT TO SHOW SITE

MUST TARGET DELIVERY FOR:

Wednesday, February 22, 2012

(Do **NOT** Deliver Before)

To:

(Your Company Name)

**SITE: Fern Exposition
Kentucky Exposition Center
937 Phillips Lane
Louisville, KY 40209
Attn: G. L. A. D. A.**

Booth Number: _____

Number _____ of _____ pieces

Return to:



EXPOSITION & EVENT SERVICES

3752 Crittenden Drive Louisville, Kentucky 40209-1122
 Telephone: 502.367.0254 Fax: 502.368.0284

WIRE MESH GRIDS ORDER FORM

DEADLINE February 9, 2012
 for return of this form:

CANCELLATION: Cancellation after deadline will be charged at 50% of prevailing rate.
LATE REQUEST: Request received after deadline will be filled as available, at the standard rate.

WIRE MESH GRID SYSTEM

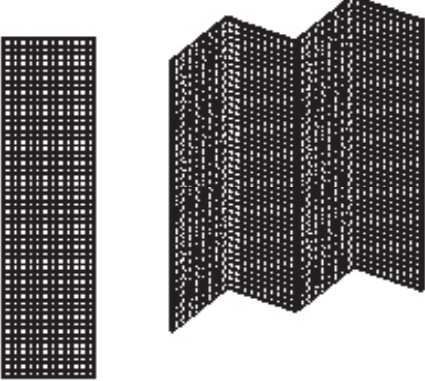
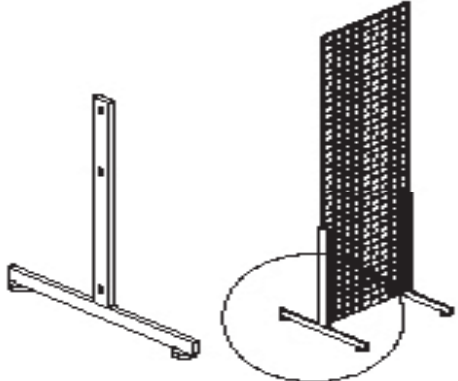
475	<p>GRID PANELS BLACK 24" X 96" (Price per panel)</p> 	476	<p>GRID LEGS BLACK (Price per leg)</p> 
------------	--	------------	---

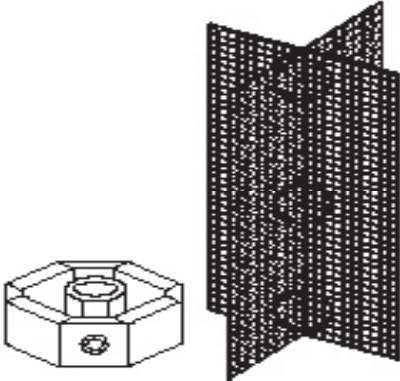
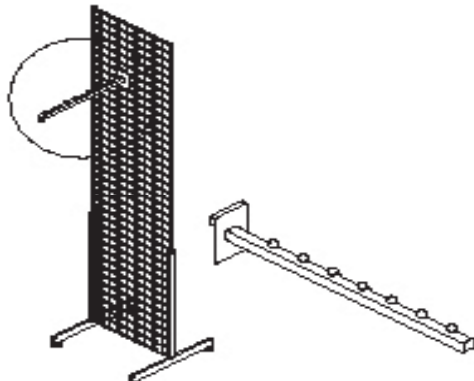
477	<p>4-WAY CONNECTORS CONNECTS 4 GRID PANELS @ 90° ANGLE (Price each connector)</p> 	478	<p>7-WAY WATERFALL BLACK (Price each)</p> 
------------	--	------------	---

Quantity	Style (See Illustrations)	Discount Rate	Standard Rate	Quantity	Style (See Illustrations)	Discount Rate	Standard Rate
_____	(475) Grid Panel, 2' x 8'	\$ 67.00 ea.....	\$ 90.50 ea	_____	(476) Grid Legs	\$ 10.50 ea.....	\$ 14.25 ea
_____	(477) 4-Way Connector	\$ 2.25 ea.....	\$ 3.00 ea	_____	(478) 7-Way Waterfall	\$ 8.25 ea.....	\$ 11.25 ea

Yes, I have completed and enclosed the Payment Form
 No credit will be given after close of event on items or services ordered, but not received.
 If you have a problem please see Fern Service Personnel at the event site prior to opening.

➡ **Sub Total :** \$ _____
6% State Tax : \$ _____
Total : \$ _____

Name of Event G.L.A.D.A. #4-1783-12 Booth# _____ Phone () _____

Firm Name _____ Fax # () _____

Address _____ E-Mail _____
Street City State Zip Code

Print/Type Name _____ Signature _____ Date _____

All orders are subject to the terms and conditions as outlined on the payment form.

Return to:



EXPOSITION & EVENT SERVICES

3752 Crittenden Drive Louisville, Kentucky 40209-1122
 Telephone: 502.367.0254 Fax: 502.368.0284

PANELBOARD RENTAL ORDER FORM

DEADLINE February 9, 2012
 for return of this form:

Cancellation: Cancellation after deadline will be 50% of prevailing rate.
Late Request: Request after deadline will be filled as available at the standard rate.
Color Choice: Choices not indicated will be selected by Fern.

PLEASE INDICATE TYPE AND STYLE OF PANEL REQUIRED.

BULLETIN BOARDS			
Quantity	Style <small>(See Illustrations) ⇨</small>	Discount Rate	Standard Rate
_____	(603) 4' x 8' Grey Velcro Style H & V only	\$ 90.00 ea.	...\$117.00 ea
<small>(Circle One)</small>			

TACKBOARD			
Quantity	Style <small>(See Illustrations) ⇨</small>	Discount Rate	Standard Rate
_____	(611) 4' x 8' tackboard panel	\$110.00 ea.	...\$143.00 ea
_____	(609) 2' x 8' tackboard panel	\$ 90.00 ea.	...\$117.00 ea
Covered in your selection of colored vinyl to coordinate with your display.			
<input type="checkbox"/>	(06) Blue	<input type="checkbox"/>	(08) Yellow
<input type="checkbox"/>	(16) White	<input type="checkbox"/>	(04) Black
<input type="checkbox"/>	(11) Maroon	<input type="checkbox"/>	(10) Green
<input type="checkbox"/>	(14) Red	<input type="checkbox"/>	(07) Brown

PERFORATED BOARD			
Quantity	Style <small>(See Illustrations) ⇨</small>	Discount Rate	Standard Rate
_____	(615) 4' x 8' perf. board panel	\$ 90.00 ea.\$117.00 ea
_____	(613) 2' x 8' perf. board panel	\$ 75.00 ea.\$ 97.50 ea
Perforated board is painted white but may be painted in a solid color of your selection at additional cost of ...			
_____	(619) Special color for 4'x8' (additional)	\$ 50.00 ea.\$ 65.00 ea
_____	(617) Special color for 2'x8' (additional)	\$ 50.00 ea.\$ 65.00 ea
Specify color _____			
Perforated board hooks NOT provided. 1/4" size hooks required.			

SHELVING (FOR PERORATED BOARD ONLY)			
Quantity	Style <small>(See Illustrations) ⇨</small>	Discount Rate	Standard Rate
_____	(631) 4' long x 6" deep-white	\$ 12.00 ea.\$ 15.50 ea
_____	(635) 8' long x 6" deep-white	\$ 21.00 ea.\$ 27.50 ea
_____	(637) Special color (per shelf addition)	\$ 12.00 ea.\$ 15.50 ea
Specify color _____			

LABOR (REQUIRED FOR STYLE B & C)			
_____	(1036) _____ hr. labor s/t		\$60.00
_____	(1036) _____ hr. labor o/t		\$120.00

STYLES	
	<p>STYLE "H" Horizontal (1) 4' x 8' (1) 2' x 8'</p>
	<p>STYLE "V" Vertical (1) 4' x 8' (1) 2' x 8'</p>
	<p>STYLE "B" Style B requires (2) 4' x 8' panels and (1) 2' x 8' panel per 10' wide backboard. *Plus labor to install minimum 1 hour</p>
	<p>STYLE "C" Style B requires (2) 4' x 8' panels and (1) 2' x 8' panel per 10' backboard. Side wings can be ordered as either (2) 4' x 8' panels or (2) 2' x 8' panels. *Plus labor to install minimum 1 hour</p>

Please indicate below the desired depth of side wings and be sure to include side wing returns in your order for Style "C".
 2' deep 4' deep

Yes, I have completed and enclosed the Payment Form
 No credit will be given after close of event on items or services ordered, but not received. If you have a problem please see the Fern Service Desk Personnel at the event site prior to leaving.

⇨ **Sub Total Equipment (taxable):** \$ _____
6% Tax on Equipment: \$ _____
Labor: \$ _____
Total: \$ _____

Name of Event G.L.A.D.A. #4-1783-12 Booth# _____ Phone () _____
 Firm Name _____ Fax # () _____
 Address _____ E-Mail _____
Street City State Zip Code
 Print/Type Name _____ Signature _____ Date _____

Return to:



EXPOSITION & EVENT SERVICES

3752 Crittenden Drive Louisville, Kentucky 40209-1122
 Telephone: 502.367.0254 Fax: 502.368.0284

SIGN AND ART WORK ORDER FORM

DEADLINE February 9, 2012
 for return of this form:

Cancellation: No refunds on orders cancelled after deadline.
Late Request: Request after deadline will be filled as available at the standard rate.
Color Choice: Choices not indicated will be selected by Fern.

This form is to be used for ordering special signs or artwork (NOT your booth I.D. Sign). There are two types of sign styles available to choose from. The first is signs created using computer cut vinyl graphics. These are good for one, two, or three color simple signs in solid colors. For more elaborate artwork with color gradients, we offer full color digital signs. Complex process color logos are an example of this. Prices indicated below are based on preparation of sign from customer copy or, if digital, computerized artwork supplied.

PRESSURE SENSITIVE VINYL SIGNS	FOUR COLOR DIGITAL SIGNS
--------------------------------	--------------------------

Prices indicated below are based upon 10 words per card and one color copy on white background. Signs other than sizes listed below will be prepared on a pro-rata price basis. Minimum order - \$ 30.00	Prices indicated below are based upon process color printing, mounting, and laminating on showcard or foamcore. Signs other than sizes listed below will be prepared on a sq/ft. basis, rounded to the nearest 1/2 ft. x 1/2 ft. Minimum order - \$ 35.00
--	---

Qty.	Code	Description	Discount Rate	Standard Rate	Amount	Qty.	Code	Description	Discount Rate	Standard Rate	Amount
_____	(801)	7" x 11" Card.....	\$ 35.00.....	\$ 52.50	\$ _____	_____	(861)	7" x 11" Card.....	\$ 45.00.....	\$ 67.50	\$ _____
_____	(803)	11" x 14" Card.....	\$ 40.00.....	\$ 60.00	\$ _____	_____	(863)	11" x 14" Card.....	\$ 50.00.....	\$ 75.00	\$ _____
_____	(805)	14" x 22" Card.....	\$ 45.00.....	\$ 67.50	\$ _____	_____	(865)	14" x 22" Card.....	\$ 60.00.....	\$ 90.00	\$ _____
_____	(807)	7" x 44" Card.....	\$ 45.00.....	\$ 67.50	\$ _____	_____	(867)	7" x 44" Card.....	\$ 60.00.....	\$ 90.00	\$ _____
_____	(811)	14" x 44" Card.....	\$ 65.00.....	\$ 97.50	\$ _____	_____	(871)	14" x 44" Card.....	\$ 85.00.....	\$ 127.50	\$ _____
_____	(813)	22" x 28" Card.....	\$ 70.00.....	\$ 105.00	\$ _____	_____	(873)	22" x 28" Card.....	\$ 90.00.....	\$ 135.00	\$ _____
_____	(815)	28" x 44" Card.....	\$ 90.00.....	\$ 135.00	\$ _____	_____	(875)	28" x 44" Card.....	\$ 105.00.....	\$ 157.50	\$ _____
_____	(819)	24" x 96" Foamcore.....	\$ 200.00.....	\$ 300.00	\$ _____	_____	(879)	24" x 96" Foamcore.....	\$ 264.00.....	\$ 396.00	\$ _____
_____	(821)	48" x 96" Foamcore.....	\$ 250.00.....	\$ 375.00	\$ _____	_____	(881)	48" x 96" Foamcore.....	\$ 576.00.....	\$ 864.00	\$ _____
_____	(899)	Other _____ x _____	Call for Quote		\$ _____	_____	(882)	Other _____ x _____	\$16.50/sq/ft..	\$24.75/sq/ft	\$ _____
_____	(827)	Easel back for card signs .	\$ 10.00.....	\$ 15.00	\$ _____	_____	(883)	Sentra _____ x _____	\$18.00/sq/ft..	\$27.00/sq/ft	\$ _____
_____	(829)	Words in excess of 10.....	\$ 1.50.....	\$ 2.25	\$ _____	_____	(827)	Easel back for card signs .	\$ 10.00.....	\$ 15.00	\$ _____
_____	(831)	Colored card	\$ 7.50.....	\$ 11.25	\$ _____						
_____	(833)	Additional color lettering \$	7.50.....	\$ 11.25	\$ _____						

Emblems, trademarks, logos, special style lettering, etc., can be prepared at extra cost depending on size and amount of work involved in production. Advance quotations can be provided upon submission of copy.

Emblems, trademarks, logos, special style lettering, etc., are *inclusive* of the above prices, if provided to us in digital format. Please provide in a PC vector format if available, or PC Raster is the second option. If you can only provide in Mac format, we will attempt to convert, but cannot guarantee 100% accuracy in conversion. If you have any questions on formats supported, please call.

PLEASE INDICATE COLOR OF SIGN AND LETTERING:	PLEASE CHECK TYPE OF SIGN DESIRED:
--	------------------------------------

COLOR OF BACKGROUND _____ COLOR OF LETTERING _____	Vertical Sign <input type="checkbox"/> Horizontal Sign <input type="checkbox"/>
---	---

INDICATE SIGN COPY

[] See Attached

Yes, I have completed and enclosed the Payment Form

No credit will be given after close of event on items or services ordered, but not received. If you have a problem please see the Fern Service Desk Personnel at the event site prior to leaving.

Sub Total: \$ _____
6% State tax: \$ _____
TOTAL: \$ _____

Name of Event G.L.A.D.A. #4-1783-12 Booth# _____ Phone () _____
 Firm Name _____ Fax # () _____
 Address _____ E-Mail _____
 Street City State Zip Code
 Print/Type Name _____ Signature _____ Date _____

Return to:



EXPOSITION & EVENT SERVICES

3752 Crittenden Drive Louisville, Kentucky 40209-1122
Telephone: 502.367.0254 Fax: 502.368.0284

AUDIO-VISUAL EQUIPMENT RENTAL ORDER FORM

DEADLINE February 9, 2012
for return of this form:

Cancellation: Cancellation after deadline will be 75% of prevailing rate.
Late Request: Request after deadline will be filled as available at the standard rate.

Delivery of Audio Visual equipment is conducted approximately 1 hour PRIOR to show opening. A Booth Delivery / Pick-up Charge of \$60.00 will be assessed on all Audio Visual Orders. This charge is non-taxable, and is included in the calculations below. Equipment will be removed immediately following final closing of event. If you have a need for any equipment that is not listed below, please direct your inquiries to the address, fax or phone number listed above.

FLAT PANEL DISPLAYS

Table with 5 columns: QUANTITY, DESCRIPTION, DISCOUNT RATE, STANDARD RATE, EXTENSION. Lists various flat panel displays and plasma panels with their respective rates.

AUDIO / VIDEO EQUIPMENT

Table with 5 columns: QUANTITY, DESCRIPTION, DISCOUNT RATE, STANDARD RATE, EXTENSION. Lists various audio and video equipment like monitors, DVD players, and sound systems.

RENTAL AGREEMENT: It is understood and agreed the customer is renting the equipment for a specific period only, and is responsible for its safe return. Customer agrees to be billed for any loss of, or damage to, rented equipment.

No credit will be given after close of event on items or services ordered, but not received. If you have a problem please see the Fern Service Desk personnel at the event site prior to opening.

Charges listed above are rental rates (not sale). If technician is required, an added cost may be incurred.



Sub Total Equipment (taxable): \$
6% Tax on Equipment: \$
Booth Delivery / Pick-up Fee: \$ 60.00
Total: \$

Yes, I have completed and enclosed the Payment Form

Name of Event G.L.A.D.A. #4-1783-12 Booth# Phone ()
Firm Name Fax # ()
Address Street City State Zip Code E-Mail
Print/Type Name Signature Date

Return to:



EXPOSITION & EVENT SERVICES

3752 Crittenden Drive Louisville, Kentucky 40209-1122
Telephone: 502.367.0254 Fax: 502.368.0284

FLORAL RENTAL ORDER FORM

DEADLINE February 9, 2012
for return of this form:

Cancellation: Cancellation after deadline will be 75% of prevailing rate.
Late Request: Request after deadline will be filled as available at the standard rate.
Color Choice: Choices not indicated will be selected by Fern.

Please indicate Selections by Circling

Table with 4 columns: POTTED PLANTS - Indicate Color Selection, DISCOUNT, STANDARD, COST. Rows include Azaleas, Bromeliads, Chrysanthemums, and Ferns.

Table with 4 columns: TROPICAL GREEN PLANTS, DISCOUNT, STANDARD, COST. Rows include 3 Ft., 4 Ft., 5 Ft., 6 Ft., and 7 Ft. plants.

ALL CONTAINERS FOR TROPICAL GREEN PLANTS WILL BE PROVIDED IN A WHITE WICKER OR DARK RATTAN
PLEASE CIRCLE CHOICE: WHITE DARK

Table with 4 columns: FLOWER ARRANGEMENTS - Indicate Color Selection, DISCOUNT, STANDARD, COST. Row includes Table Top, 10" Baskets of cut flowers.

SPECIAL REQUIRMENTS AND LANDSCAPING - other than items listed above

Prices on bark, moss, fencing, fountains, (1573) hedge plants, (1599) general landscaping are available when submitting "To Scale Layout of Desired".

COMPLETE THE FOLLOWING ONLY IF YOU HAVE REQUIREMENTS OTHER THAN THOSE LISTED ABOVE:

* (1599) Please have florist come to our Booth No. at A.M. / P.M. on and see our Representative for instructions. Please provide telephone # where representative can be reached in advance.

Yes, I have completed and enclosed the Payment Form

No credit will be given after close of event on items or services ordered, but not received. If you have a problem please see Fern Service Personnel at the event site prior to opening.

Sub Total: \$
6% State tax: \$
TOTAL: \$

Name of Event G.L.A.D.A. #4-1783-12 Booth# Phone ()
Firm Name Fax # ()
Address Street City State Zip Code E-Mail
Print/Type Name Signature Date

All orders are subject to the terms and conditions as outlined on the payment form.

Return to:



EXPOSITION & EVENT SERVICES

3752 Crittenden Drive Louisville, Kentucky 40209-1122
Telephone: 502.367.0254 Fax: 502.368.0284

THANK YOU RESPONSE FORM

DEADLINE February 9, 2012
for return of this form:

**PLEASE READ CAREFULLY AND
RESPOND BY DEADLINE**

Thank you for reviewing the enclosed order forms. This form has been provided to eliminate unnecessary follow-up mailings and telephone calls to you if you have no need for exhibit furnishings and/or services or if you do not anticipate placing your order until you arrive at event site
PLEASE RESPOND TO THE FOLLOWING:

PLEASE CHECK ONE:

(T) NO ORDER

After reviewing the enclosed order forms, we have determined that *we will not require* any furnishings or services from Fern.

(W) WILL ORDER AT EVENT SITE

We are unable to request our needs in advance; however, we *do anticipate ordering* items and/or services at prevailing rates & conditions from the following categories when we arrive at event site (please check):

- | | |
|-------------------------------|---------------------------------------|
| _____ Exhibit Furniture | _____ Custom Furniture |
| _____ Exhibit / Custom Carpet | _____ Panelboard |
| _____ Sign / Artwork | _____ Display Labor |
| _____ In-Booth Forklift | _____ Cleaning |
| _____ Floral Rental | _____ Drayage / Freight Services |
| _____ Wire Mesh Grid | _____ Audio / Visual Equipment Rental |
| _____ Fern Transportation | _____ Misc. (list) _____ |

(Some furnishings and/or services listed above may not be available at this particular event. Please check order forms. If not offered, please feel free to inquire with our office. Also note that you may find some services above are provided by someone other than Fern. See letterhead of each form and contact appropriate company regarding your intent to order at event site.)

CONTACT SOMEONE ELSE REGARDING OUR EXHIBIT NEEDS

I am not the person responsible for the ordering of exhibit furnishings and services.

PLEASE CONTACT THE FOLLOWING INDIVIDUAL:

Name _____ Phone () _____
Company Name _____
Mailing Address _____
City / State / Zip _____

PLEASE RETURN THIS FORM TO AVOID UNNECESSARY MAILINGS AND CALLS !

Name of Event **G.L.A.D.A. #4-1783-12** Booth# _____ Phone () _____
Firm Name _____ Fax # () _____
Address _____ E-Mail _____
Street City State Zip Code
Print/Type Name _____ Signature _____ Date _____

Return to:



EXPOSITION & EVENT SERVICES

3752 Crittenden Drive Louisville, Kentucky 40209-1122
Telephone: 502.367.0254 Fax: 502.368.0284

INDEPENDENT DISPLAY HOUSE/
CONTRACTOR NOTIFICATION

DEADLINE February 9, 2012
for return of this form:

Complete and return this form by Deadline only if you are
planning to use any company other than Fern
for the installation or dismantling of your exhibit.

INDEPENDENT DISPLAY HOUSE CONTRACTORS

[] Yes, we will be using an independent display house/contractor to install and/or dismantle our display at the
G.L.A.D.A. in Louisville, KY and have completed the following information.

Exhibiting Company Name: Booth No.

Exhibiting Contact Person:

Exhibiting Company Telephone Number:

Contractor To Be Utilized (Company Name):

Address:

Contractor Telephone Number:

Contractor Contact Name:

Email Address:

INDICATE WHAT SERVICES ARE TO BE CHARGED TO THIRD PARTY

* See the letterhead of each individual order form to confirm what company is providing services ordered on that specific form. This third party billing
information above and below is for use by Fern only, therefore if a service that you have ordered is being provided by someone other than Fern, you need not indicate
that particular service below:

- (01) EXHIBIT FURNITURE RENTAL ORDER
(03) EXHIBIT / CUSTOM CARPET RENTAL ORDER
(08) SIGN AND ART WORK ORDER
(12) DRAYAGE SERVICES ORDER
(17) AUDIO/VISUAL EQUIPMENT RENTAL ORDER
(99) MISCELLANEOUS - LIST
(43) CUSTOM FURNITURE RENTAL ORDER
(06) PANELBOARD RENTAL ORDER
(10) IN-BOOTH FORKLIFT
(10) DISPLAY LABOR
(09) CLEANING SERVICES ORDER
(15) FLORAL RENTAL ORDER
(12) FERN TRANSPORTATION

NOTE: Some order forms for furnishings and/or services listed above may not be enclosed if a specific service or item is not offered on this event.
If you have any questions, please contact George Fern Co.

* Exhibiting company clearly understand that exhibiting company is ultimately responsible for payment of any and all services invoiced third party which remain
unpaid at close of show.

[] I have notified our independent display house/contractor of the rules and regulations requiring them to submit a
Certificate of Insurance to the Official Show Contractor, Fern, by above Deadline Date.

Signature Date Print or Type Your Name

Name of Event G.L.A.D.A. #4-1783-12 Booth# Phone ()

Firm Name Fax # ()

Address Street City State Zip Code E-Mail

Print/Type Name Signature Date

Policy Regarding Official Service Contractor And Regulations For Exhibitor Appointed Independent Display House Contractors To Install and Dismantle Displays

The Official Service Contractor is appointed to:

- a. Insure the orderly and efficient installation and removal of the overall exposition,
- b. Assure the distribution of labor to all Exhibitors according to the need,
- c. Provide sufficient labor to satisfy the requirements of Exhibitors, and for the exposition itself,
- d. See that the proper type and limits of insurance are in force, and
- e. Avoid any conflict with local union and/or exhibit hall regulations and requirements.

The Official Service Contractor will provide all usual trade show services, including labor. Exceptions are:

- f. Supervision may be provided by the Exhibitor.
- g. The Exhibitor may appoint an outside independent contractor for installation and dismantle only of the Exhibitor's display.

Exhibitors may employ the service of independent contractors to supervise the installation and dismantlement of their displays, providing the Exhibitor and the installation and dismantling contractor comply with the following requirement:

1. The Exhibitor, in writing, must notify Show Management and Fern of their intention to utilize an independent contractor no later than 25 days prior to the first move-in day, furnishing the name, address and telephone number of the firm. Letters such as from independent contractors are neither valid nor acceptable.
2. Only the one Exhibitor named independent contractor's employees will be authorized on the show floor. Employees of third parties named or subcontracted by the Exhibitor named independent contractor will not be authorized admittance on the show floor unless those employees are named and badged as specified in the following article.
3. The independent contractor must furnish Show Management and Fern with the names of all on-site employees who will be working on the exposition floor prior to the first move-in day and see that they have and wear at all times identification badges supplied by the independent contractor containing the independent contractor name, employee name and Exhibitor Company name, plus wear an exhibitor work pass supplied by Show Management.
4. The independent contractor must have all business licences, permits and Workman's Compensation insurance required by the State and City governments and the Convention Center Management prior to commencing work, and shall provide Show Management and Fern with evidence of compliance.
5. The independent contractor must carry a minimum of \$1,000,000 in Public Liability Insurance and shall provide Show Management and Fern with a certificate of insurance showing the coverages and amounts, and naming the sponsor, Fern and the Convention Center as co-insured.
6. The independent contractor must follow the scheduled work times or pay any additional costs incurred because of extended work hours.
7. The independent contractor may not solicit business on the exhibit floor.
8. The independent contractor must confine their operations to the exhibit area of their clients. No service desks, storage areas or other work facilities will be located anywhere else in the building. The show aisles and public space are not part of the Exhibitor's booth space.
9. The independent contractor must comply with all labor agreements and practices and must not commit or allow to be committed by persons in their employment any acts that could lead to work stoppages, strikes or labor problems.
10. The exposition floor, aisles, loading docks, services and storage areas will be under the control of the Official Contractor Fern.
11. For services such as electrical, plumbing, telephone floral, booth cleaning and drainage, no contractor or support other than the Official Service Contractor/Supplier will be approved. This regulation is necessary because of licensing, insurance, and work done on equipment and facilities owned by parties other than the Exhibitors. Exhibitors shall provide only the material and equipment they own and is to be used in their exhibit space.